

PROGRESSIVE BUFFERS TYPE C



Rigid buffers used as end stops or to limit the stroke of moving parts give rise to high impact stresses to structures often causing visible deterioration. This is normally accompanied by unacceptably high noise levels to the human ear particularly when these impacts are repeated periodically. Rubber buffers eliminate these drawbacks considerably, as they dampen noise and absorb energy. The simple buffer has a flat surface and therefore responds immediately to impact, without over-extending the stroke of the moving part. The progressive buffer has a conical form and therefore makes contact on a progressive basis, increasing deflection with increasing load. This action provides gradual arrest of moving parts absorbing considerable energy, prohibiting instant high impact stress.

TECHNICAL CHARACTERISTICS

These buffers are made with a rubber compound permitting major deformations under impact with notable absorption of energy. They can be made with high-damping rubber to order, however, absorption of energy in high damped compounds is performed with reduced rebound movement and with slightly higher transfer levels of stress to the structure.

APPLICATIONS

As buffers: In limiting impact stress; End of stroke of spring or damper. • End of stroke of cranes and hoists. • Supporting fragile material or machinery in packaging.

applications

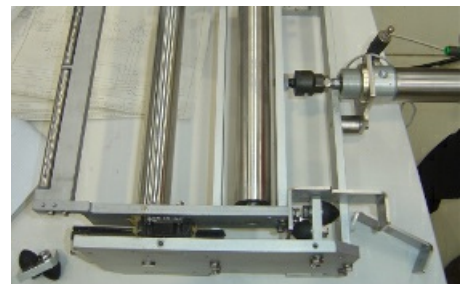
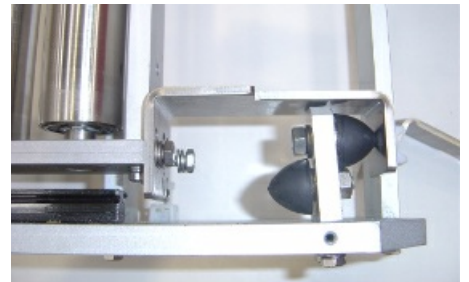

DRAWINGS

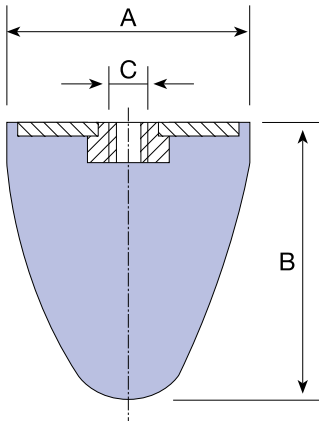

DIMENSIONS

| Type | A (mm) | B (mm) | C (mm) | Load (kg) | Weight (kg) | Energy (Nm) | Dynamic Deflection mm | Code |
|---------|--------|--------|--------|-----------|-------------|--------------|-----------------------|--------|
| T-25 | 25 | 19 | M-8 | 100 | 0,018 | 3 | 8 | 115008 |
| T-30xM6 | 30 | 30 | M-6 | 140 | 0,025 | 6 | 15 | 115009 |
| T-30xM8 | 30 | 30 | M-8 | 140 | 0,025 | 6 | 15 | 113129 |
| T-50x50 | 50 | 50 | M-8 | 340 | 0,106 | 30 | 25 | 115010 |
| T-50x58 | 50 | 58 | M-8 | 400 | 0,114 | 37 | 28 | 115012 |
| T-50x64 | 50 | 64 | M-8 | 370 | 0,132 | 40 | 32 | 115011 |
| T-70 | 72 | 58 | M-12 | 550 | 0,213 | 50 | 26 | 115014 |
| T - 85 | 84 | 52 | M-12 | 1500 | 0,315 | 200 | 20 | 116011 |
| T-95 | 94 | 80 | M-16 | 1100 | 0,516 | 120 | 37 | 115015 |

DRAWINGS

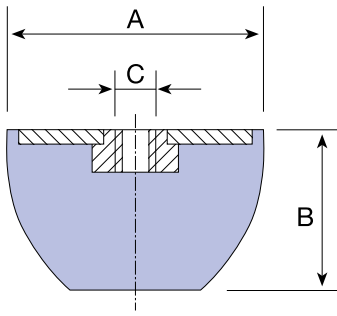

DIMENSIONS

| Type | A (mm) | B (mm) | C (mm) | Load (kg) | Weight (kg) | Energy (Nm) | Dynamic Deflection mm | Code |
|---------|--------|--------|--------|-----------|-------------|-------------|-----------------------|--------|
| T - 120 | 120 | 75 | M-16 | 3000 | 0,933 | 340 | 22 | 116012 |
| T - 220 | 220 | 137 | M-24 | 15000 | 5,66 | 2500 | 40 | 116013 |

OPERATION AND ASSEMBLY



These buffers can be used in these two ways: As actual buffers - impact taking place at the end of stroke, taking into account the maximum deflection the stop has to give. As flexible mounts where the buffers may be screwed to the base of the machine so that its flat surface rests directly on the floor or ground.

ADVANTAGES



Easy to install . ; High efficiency when used as mount or buffer.; Flexibility in moving machines which are not secured to the floor or ground, or of moving the buffers to different points where ends of stroke may be made.



AMC MECANOCAUCHO
Industrialdea Zona A - Pab. 35.
Asteasu E-20159, Gipuzkoa
Spain



Tel.: +34 943 69 61 02
Fax: +34 943 69 62 19



sales@amcsa.es



www.mecanocaucho.com
www.akustik.com