

TABLA DE TOLERANCIAS GENERALES PARA PARTES METÁLICAS GENERAL TOLERANCES TABLE FOR METAL PARTS	MAYOR DE - LARGER THAN (mm)	0,5	3	6	30	120	400	1000
	HASTA - UP TO (mm)	3	6	30	120	400	1000	2000
	TOL. (mm)	±0,1	±0,1	±0,2	±0,3	±0,5	±0,8	±1,2

ROSCAS METRICAS SEGUN:
METRIC THREADS ACCORDING TO: DIN 13

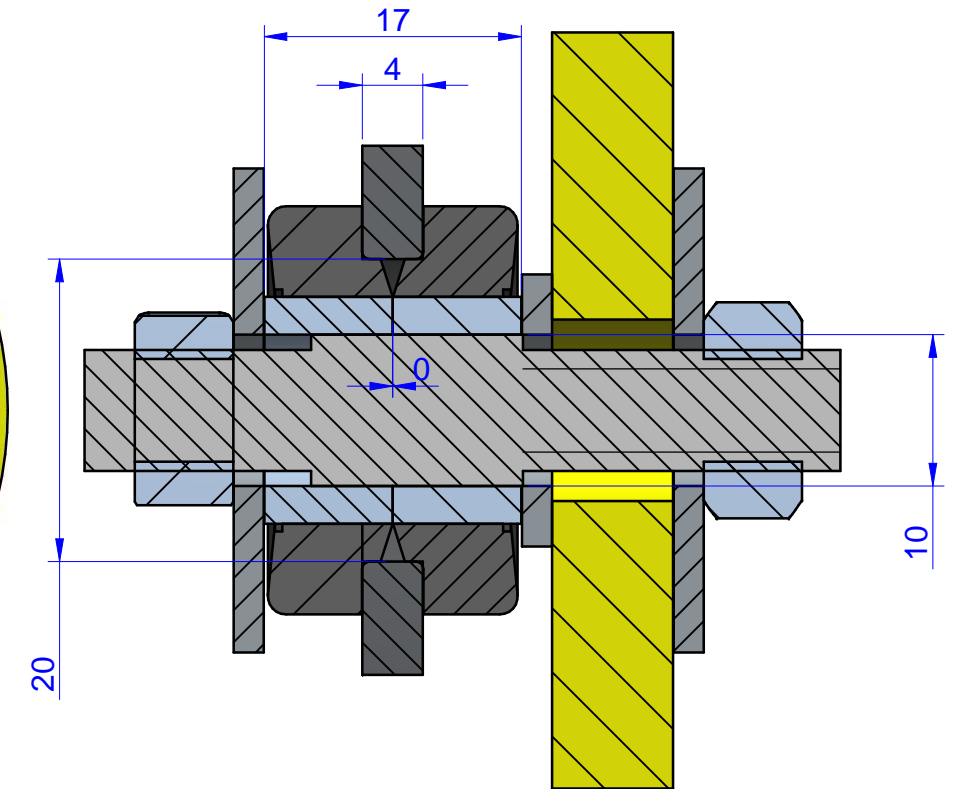
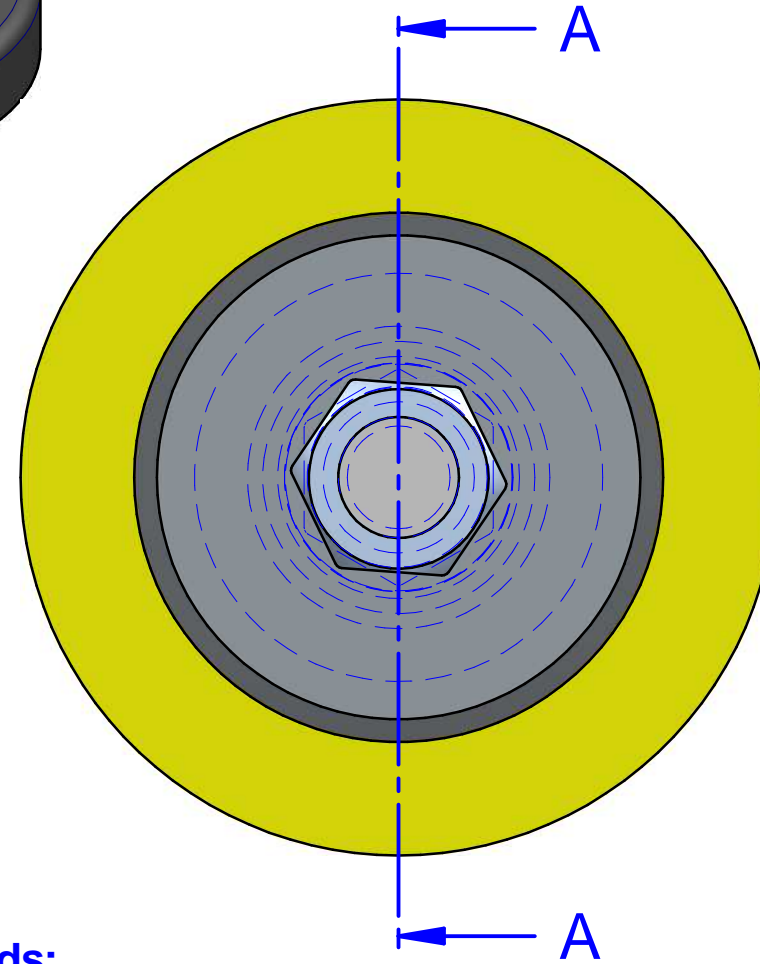
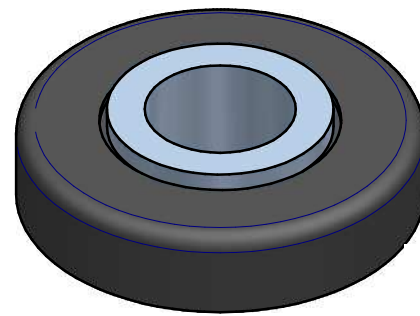
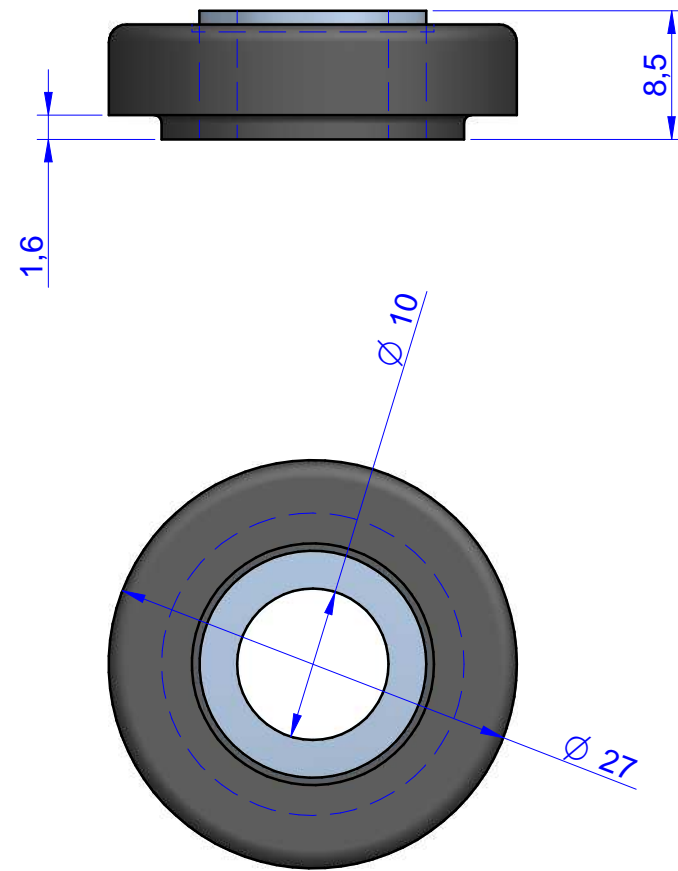

CORTE A-A

- Assembly of two isentical rubber to metal components each fixing point need two rubber to metal elements
- The part can be manufactured with two different compounds:
 - EPDM
 - NR-EPDM

ESTE PLANO ES PROPIEDAD DE AMC S.A. TODOS LOS DERECHOS RESERVADOS NO ESTA PERMITIDA LA REPRODUCCION O COPIA DE ESTE PLANO O PARTE DEL MISMO SIN UNA AUTORIZACION ESCRITA POR PARTE DE AMC S.A.

THIS DRAWING IS PROPERTY OF AMC S.A. ALL RIGHTS RESERVED. ANY COPY OR REPRODUCTION OF THIS DRAWING TOTALLY OR PARTIALLY IS STRICTLY PROHIBITED WITHOUT WRITTEN AUTHORISATION OF AMC S.A.

Rev.	Modificación-Aldarazpena-Modification	Realizado-Egina-Done	Fecha-Data-Date	
Denominación Izena Name	Assembly new TF20	Peso-Pisua-Weight Escala Eskala Scale	2:1	
Material Materiala Material	MATERIAL	Referencia - Erreferentzia - Part Number	XXX	
Tratamiento Tratamendua Treatment	-			
	Dibujado - Marraztuta - Drawn			Aprobado - Onartua - Approved
Nombre - Izena - Name	AUTOR			
Fecha - Data - Date	17-05-2016			